

INSTALLATION INSTRUCTIONS

2000-2007 KTM 250-380 2 STROKE FLYWHEELS

STEP 1: BEFORE YOU BEGIN

WARNING

ALL TRAILTECH FLYWHEELS WILL CHANGE THE PERFORMANCE OF YOUR KTM. It is highly recommended that you spend the time necessary to familiarize yourself with the performance changes, and become comfortable with the way the bike produces power with the new part. KTM two stroke bikes use a dry oil system; we recommend you lightly coat the flywheel with grease to prevent rust.

You will need a KTM Two Stroke flywheel puller (Trail Tech P/N 6200-P01) for this installation. A new gasket may be necessary (Trail Tech P/N 6300-G02.)

STEP 2: INSTALL FLYWHEEL

1. Shut the gas supply off on the bike.
2. Remove the shifter bolt and shifter.
3. Remove the (4) m6 bolts holding the side cover on.
4. Use a 17mm socket and impact ratchet to remove the flywheel retaining nut. If an air ratchet is not available, place the bike in 4th or 5th gear and hold the rear brake while removing the 17mm flywheel nut.
5. Use flywheel puller to remove the flywheel (Trail Tech P/N 6200-P01).
6. Install new flywheel. Replace OEM flywheel nut and torque to OEM torque spec. of 60Nm (44ft lbs). Do not use thread locking compound.
7. Replace the side case. Use a new gasket if necessary. Torque side case bolts to 10Nm (7.2ft lbs). Do not overtighten these bolts.
8. Replace the shifter. Make sure the bolt threads in smoothly - cross threading is easy.

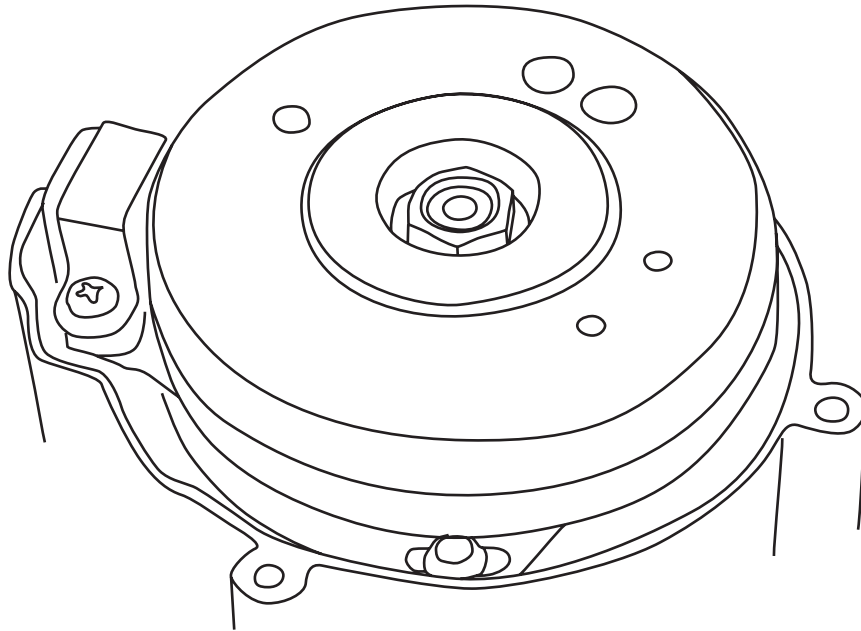

LIMITED WARRANTY

TRAILTECH INC. WARRANTS TRAIL TECH FLYWHEEL PRODUCTS TO BE FREE FROM DEFECTS IN MATERIAL AND WORKMANSHIP UNDER NORMAL USE AND IF PROPERLY INSTALLED FOR A PERIOD OF SIX MONTHS FROM DATE OF PURCHASE. IF FOUND TO BE DEFECTIVE AS MENTIONED ABOVE, IT WILL BE REPLACED OR REPAIRED. THIS SHALL CONSTITUTE THE SOLE REMEDY OF THE PURCHASER AND THE SOLE LIABILITY OF TRAILTECH INC. TO THE EXTENT PERMITTED BY LAW, THE FOREGOING IS EXCLUSIVE AND IN LIEU OF ALL OTHER WARRANTIES OR REPRESENTATIONS WHETHER EXPRESSED OR IMPLIED, INCLUDED ANY LIMITED WARRANTY OF MERCHANTABILITY OR FITNESS. IN NO EVENT SHALL TRAILTECH INC. BE LIABLE FOR SPECIAL OR CONSEQUENTIAL DAMAGES.